

# MANUAL 2024

Installation of the WaterWorld CANopen  
inboard systems

Dear reader,

Congratulations on your purchase! We are delighted that you have chosen a WaterWorld propulsion system.

The WaterWorld engines are designed and produced with the utmost care. Everything is focused on providing you with a safe, reliable, environmentally friendly, and user-friendly propulsion system that you can enjoy using.

We strive to continually improve WaterWorld propulsion systems. If you have any comments about the design or use of the system, we would greatly appreciate it if you could inform us. The contact details can be found on the back of this manual.

We recommend that you carefully read this manual so that you can install and use this propulsion system correctly. We wish you a lot of enjoyment with it!

The WaterWorld team



# TABLE OF CONTENTS

## 1. INTRODUCTION

Use of this manual.....	7
Warning and symbols .....	7
Serial numbers .....	8

## 2. PRE-INSTALLATION CHECKLIST

Step-by-step installation guide.....	11
--------------------------------------	----

## 3. SAFETY

General guidelines .....	13
Safety features of the propulsion system .....	14
Safety instructions for the propulsion system .....	15
Safety instructions for the batteries.....	16
Safety instructions for usage .....	17

## 4. DELIVERY CONTENTS

Contents of the WaterWorld package .....	19
--	----

## 5. SYSTEM INSTALLATION

Connection diagram .....	25
Placement of the inboard moto.....	26
Batteries .....	28
Battery charger .....	29
Recommended cable thicknesses .....	29
Main power switch.....	30
Main fuse .....	30
The relay .....	31
The throttle .....	31
The display .....	32
The ignition switch .....	32
Connecting the throttle, display, and ignition switch .....	32
Setting up the display .....	33
Testing and commissioning.....	36

## 6. OPERATION OF THE MOTOR

Starting and setting off .....	39
Explanation of the display .....	40
Arriving and docking .....	43

## 7. MAINTENANCE AND SERVICE

Checks during the boating season .....	45
Annual checks by you or your supplier .....	46
Winter storage .....	47
Using the motor in saltwater .....	47

## 8. TECHNICAL SPECIFICATIONS

Motor specifications .....	49
Electric motor .....	49
Motor controller .....	49
Control lever .....	49
Relay .....	49
Display .....	50
Propeller selection guidelines .....	51

## 9. TROUBLESHOOTING AND PROBLEM SOLVING

Error codes for malfunctions .....	53
Warnings .....	53
Errors .....	54
Issues .....	55

## 10. WARRANTY

Warranty periods.....	57
Warranty terms .....	57
Warranty procedure .....	58
Disposal of the product / recycling .....	59

## 11. APPENDICES

Ray-link .....	61
Ray-link connection diagram .....	61
VE-link .....	62
VE-link connection diagram .....	62

# CHAPTER 1 INTRODUCTION



- Use of this manual
- Warning and symbols
- Serial numbers

## Use of this manual

This manual contains essential information for the safe use of WaterWorld electric propulsion systems. Both maintenance and troubleshooting are covered in this manual.

It is crucial that anyone responsible for the installation of this system, as well as anyone who will operate the motor, thoroughly studies this manual. It is necessary to closely follow and execute the warnings and safety instructions in this manual.

The installation and maintenance of WaterWorld motors should be carried out by specialized and skilled installers, adhering to applicable laws and regulations, in conjunction with the safety aspects listed in this manual.

Keep this manual with your system in a safe and easily accessible place!  
You can download a copy or the latest version at [www.waterworldelectronics.com](http://www.waterworldelectronics.com).

## Warning and symbols



A warning indicates that there is a potential risk of injury to the user/installer or significant material damage if the user or installer fails to avoid this risk.



Special information, respective requirements and prohibitions regarding damage prevention.

**WARNING!**

Instructions that require extra attention and must be followed.

## Serial numbers

You will find the identification label with the serial number on the top of the motor controller. It indicates the manufacturer, the model number, and the unique serial number of the motor or controller. The serial number starts with the letters WW and is listed after the text 'Serial:'. Below, there is another text starting with WW (21113085), which is the article number of the motor controller.



The inboard motor has its own serial number.

## Inboard motor



Both numbers should be found on your invoice. This can be important for warranty purposes.

## Motor controller



**WARNING!** Never remove the identification labels and/or other stickers on the motor.

# CHAPTER 2

## PRE-INSTALLATION CHECKLIST



### • Step-by-step installation guide

### Installation step-by-step guide

#### 1. Read the manual

We aim to provide you with an extremely comprehensive manual. This includes not only aspects related to the WaterWorld inboard motor, but also information about the entire boat, the propeller, and the batteries. However, it is important to note that each installation is unique and should be carried out by a skilled person.

#### 2. Check if you have received everything that should be included in the delivery.

Arrange all parts neatly and compare them with the list in Chapter 4 of this manual and the attached packing slip. If you have any questions, please contact your supplier directly for clarification.

#### 3. Prepare the boat to install the system in a clean and dry environment.

If the following aspects do not meet the requirements, they should be addressed before installation.

1. No permanent bilge water at the motor installation location:  
Ensure that there is no permanent bilge water present at the location where the motor is to be installed.
2. Effective protection against boat flooding:  
Ensure a properly functioning bilge pump is in place in the boat to prevent flooding.
3. Considerations for component placement:  
Prevent leakage or condensation moisture from above when placing components. Adjust placement if necessary or cover components from above.
4. Ensure good ventilation:  
Provide adequate ventilation in the relevant space(s) to allow moisture to evaporate and ventilate the space. Ensure good "flow-through".
5. Smooth-running and properly aligned propeller shaft system:  
Check if the propeller shaft system runs smoothly and is properly aligned. A stiff-running propeller shaft system can lead to;  
Increased fuel consumption, resulting in reduced operating time.  
Engine overheating  
Slow response to throttle input.  
Less controlled throttle; the engine may start with too much power once sufficient force has been built up.
6. Ensure these points are addressed before proceeding with installation.

#### 4. Make the right propeller selection.

Refer to our advice on page 44.

#### 5. Check the accessibility of the components.

Ensure that all components remain accessible for servicing.

#### 6. Ensure proper weight distribution in the boat.

The (lead-)battery pack can be significantly heavy; ensure balanced weight distribution in the boat. Ensure that the batteries are accessible for maintenance of the battery terminals, wiring, and in the case of wet batteries, for topping up with distilled water. For WaterWorld LFP batteries, it is essential that the on/off switch is accessible at all times.

#### 7. Choose the correct cable thickness.

Refer to page 27 for the correct cable selection. Ensure that cable lengths are not unnecessarily long if this can be avoided. To ensure equal discharge of potentially multiple batteries, it is important that the lengths of both the cable from the main positive terminal and the main negative terminal are equal.

#### 8. Read the safety instructions in Chapter 3 before connecting anything.

Then read the section of the manual that pertains to the respective component. Always connect according to the connection diagram on page 23.

#### 9. Start the installation.

# CHAPTER 3

## SAFETY



- **General guidelines**
- **Safety features of the propulsion system**
- **Safety instructions for the propulsion system**
- **Safety instructions for the batteries**
- **Safety instructions for usage**

### General guidelines

Read and observe the safety and warning instructions in this manual!

- Adhere to local laws and regulations and the required qualifications.
- Ignoring the instructions may result in injury and material damage. Water World Electronics cannot be held liable for damage resulting from actions contrary to this manual.
- The propulsion system should operate at the prescribed voltage. In the standard setting, this is 48 volts nominal. Minimum 42 volts, maximum 60 volts.
- The system is intended solely for powering watercraft. The manufacturer cannot be held liable for any other use, and in all cases, the warranty is void.
- Keep the electronics away from water.
- Installation and repairs may only be carried out by an authorized installer designated by WaterWorld.
- Use only original or recommended WaterWorld accessories and/or spare parts.
- Only original replacement parts may be used for repairs to the propulsion system. The use of non-original parts may result in serious injury, damage, and voiding of further warranty.
- Battery replacement must be carried out exclusively by an authorized installer.
- The user should regularly ensure the proper operation of the propulsion system and the batteries. The manufacturer is not liable for any damage resulting from the improper functioning of the propulsion system.
- The supplier, being WaterWorld, the seller, or the manufacturer, do not accept liability for any damage to the buyer, nor for potential claims from third parties arising from (the use of) the propulsion system, directly or indirectly, including consequential damage, environmental damage, hearing damage, business damage, and non-material damage, or incorrect advice, unless the damage is attributable to gross negligence or negligence of the supplier.
- Prior to use, you must consider the legislation in the respective country, both at the location where the propulsion system is located and where it is used. The buyer is responsible for complying with any legal precautions at the location where the propulsion system is used, regardless of whether the propulsion system is operational at that time. This also includes measures relating to fire safety and ensuring the safety of others in the vicinity of the propulsion system.
- The manufacturer reserves all rights and powers arising from European legislation. It is expressly prohibited to imitate or copy the device.
- For non-standard battery packs, except WaterWorld LFP batteries, it is best to contact your supplier beforehand.
- Never attempt to carry out repairs on the WaterWorld system independently.
- Never touch loose, torn, or visibly damaged cables or parts.
- Do not lift the WaterWorld system alone and use suitable lifting equipment.
- During navigation, ensure that the risk of the propeller hitting the bottom is eliminated.

## Safety features of the propulsion system

Your WaterWorld electric drive system is equipped with various safety measures:

- **Overheating protection for motor and controller:**  
The motor adjusts the power output when the electronics detect excessive temperatures.
- **Fuse on the controller:**  
Depending on the motor power, a fuse is installed on the motor controller.
- **External fuse for wiring:**  
This prevents fire, overheating, or overloading of the system. CAUTION! This external fuse is not included in the standard delivery but must be installed.
- **Main switch:**  
Make sure to always turn this off when you leave the boat or when work is being done on the system. This main switch is not included in the standard delivery but must be installed. Consult your supplier for the appropriate main switch regarding the applied current strength.
- **Overload protection for batteries:**  
If your batteries are nearly empty, the motor will automatically reduce power, allowing you to extend your sailing time and safely reach a harbor at low speed.
- **Ignition switch:**  
This allows you to turn off the system in case of danger. Always turn it off when there are swimmers around the boat!
- **Display:**  
This continuously shows the remaining sailing time, allowing you to plan your trip to reach your destination. Additionally, the display warns of excessively high or low battery voltage, with an indication on the screen for low voltage
- Voltage-carrying cables that connect the motor, controller, and other components must be regularly inspected for damage, breaks, and proper, secure attachment.
- The cable shoes of the voltage-carrying cables that connect the motor, controller, and other components must be equipped with pole caps that also cover the battery poles.
- When damage or breakage is detected in the cables/wires, the motor must be immediately shut down and taken out of service until the respective cable/wire is replaced.



**WARNING!**

## Safety instructions for the propulsion system

Follow the instructions in this manual

- Immediately switch off the system via the main switch in case of overheating, smoke development, or if you detect a defect.
- In use, the ambient temperature should not be lower than -20 degrees Celsius and not higher than 50 degrees Celsius.
- Do not touch the driveshaft, motor, and battery components during or immediately after sailing.
- Always switch off the system via the main switch during assembly and disassembly work.
- Do not perform maintenance or cleaning on the propeller or driveshaft while the system is powered on.
- **WARNING! Turn off the engine when there are people near the boat.**



**DANGER!**



## Safety instructions for the batteries

- Adhere to all safety instructions regarding the used batteries as outlined in the battery manufacturer's manual.
- Do not use the WaterWorld system if the battery is damaged, and inform the supplier or installer of the system.
- Do not store flammable objects near the battery.
- Never smoke and avoid sparks or flames near the batteries.
- Make sure you have enough water on hand; if battery acid comes into contact with the skin or eyes, immediately rinse with water and seek medical assistance.
- Only use charging cables suitable for outdoor use.
- Always fully unwind the reel from a 230 Volt power outlet if you are using one.
- Avoid strong mechanical forces on the batteries and system cables.
- Remove metal jewelry and watches before performing work on batteries and always use insulated tools for this purpose.
- Never short-circuit batteries. Ensure that tools and metal objects never come into contact with the battery to prevent sparks, fire, or explosions.
- When connecting the battery, pay attention to the correct polarity and ensure that the connections are securely and firmly attached for good contact.
- Never reverse the polarity.
- When connecting the batteries, first connect the red positive cable and then the black negative cable.
- When disconnecting the batteries, ensure that you first disconnect the black negative cable and then the red positive cable.
- Battery terminals must be clean, free from corrosion, and covered with terminal caps.
- Do not place batteries in poorly ventilated spaces. When placing them in a locker, proper ventilation must be provided.
- Only connect identical batteries (type, capacity, age).
- Only connect batteries with identical state of charge.
- Ensure that battery terminals always make optimal contact with the cable eyes they are connected to.
- Do not connect other consumers (e.g., fish finder, lights, radios, etc.) to the same battery bank used to power the inboard motor.
- In case of battery failure, it is recommended to replace all batteries.
- When working on batteries, always switch off the system using the main switch.



**DANGER!**

**WARNING! Always ensure that there are no stainless steel washers between the battery terminal and the connected cable.**

**WARNING! More information about the batteries can be found in the manuals 48-6800 and 48/35 charger on [www.waterworldelectronics.com](http://www.waterworldelectronics.com)**

## Safety instructions for usage

Read this manual thoroughly.

- The WaterWorld system may only be used by individuals who are qualified and both physically and mentally fit.
- Always comply with the national regulations and rules of the respective country.
- Keep the drive and control options out of reach of children or individuals who cannot handle them properly.
- Have the operation and safety regulations of the entire system explained by the shipyard or installer.
- Inspect the system for mechanical damage before departure.
- Check the condition and operation of all functions of the WaterWorld system at the start of each voyage at low speed.
- Sail only with a system that is in perfect technical condition.
- Ensure that the batteries are sufficiently charged.
- Familiarize yourself with all control elements of the WaterWorld system and know how to stop the system quickly if necessary.
- As the boat operator, you are responsible for the safety of the people on board and for all boats and people around you. Therefore, adhere to the basic rules of boating.
- Be extra cautious when there are people in the water, even when sailing at low speed.
- Obtain information about the area where you will be sailing before departure and take into account the weather forecasts and sea conditions.
- Be familiar with the area where you will be sailing, as the range indicated by the onboard computer does not account for wind, current, and sailing direction.
- Plan for a sufficient buffer for the required range.
- Ensure that, depending on the size of the boat, the specific safety equipment is available and accessible (life jackets, anchor, paddle, communication devices, etc.).



**DANGER!**

# CHAPTER 4 DELIVERY CONTENTS



## • Contents of the WaterWorld package

## Contents of the WaterWorld package

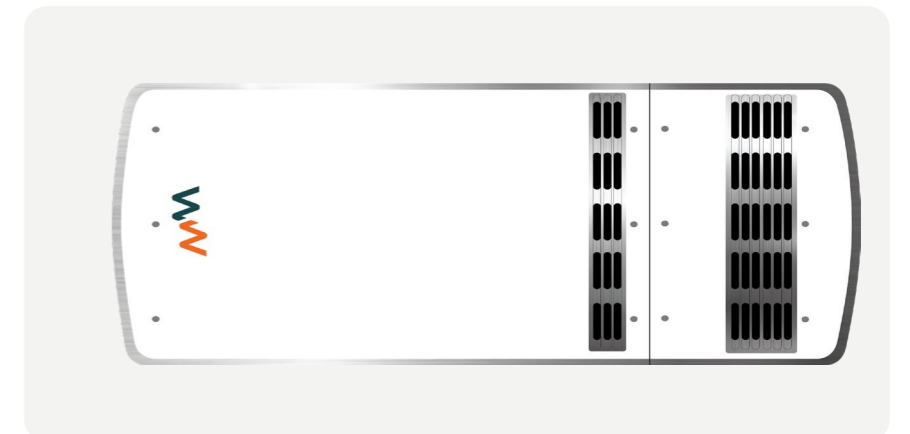
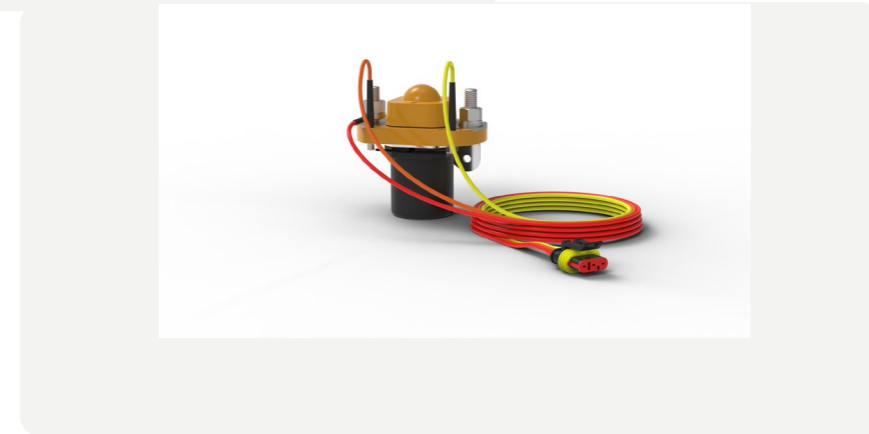

**Standard delivery package includes:**

- Inboard base module
- Motor controller with stainless steel motor mounts
- Display
- Side-mount throttle lever (top-mount optional, ask your supplier)
- Relay
- Ignition switch with 2 keys
- Data cables (included with the separate components)

**Not included:**

- Main power switch
- Fuses for individual batteries

**Motor mounts**

Adjustable attachment to the outer side of the frame.

**NOTE! During installation, the supports will be reversed, and the motor will hang in the supports instead of standing on them.**



**Propeller thrust bearing**

Integrated into the motor, the shaft has a flange for attaching a counter-flange (not included) to secure the propeller shaft (not included). In the image, you can see the flange. It should only be removed, if necessary, using a pulley puller.

**Never hit the flange with a hammer!**

In case of continuous operation at 10 kW or 20 kW, it is recommended to use an external thrust bearing



**Dashboard with ignition switch.**

Ignition switch with a 3-meter cable (easily extendable if necessary).



**Digital display**

The digital color display with touch functionality is supplied with a 3-meter RJ45 data cable. The display has an IP65 rating. When mounted in an open boat, please note that the display can become very hot in direct sunlight. We recommend covering the display with good ventilation to protect it from weather conditions when the boat is not in use. When mounting in an aluminum console, ensure the console has (natural) ventilation to prevent moisture from entering through the back of the display. Instructions for setting up and reading the display can be found on pages 32/33



**Throttle Lever**

Throttle, and RJ45 data cable (3 meters), and a gateway (from 2022, the gateway is no longer needed).





### Terminating Resistors

From 2022 (software version  $\geq 1.31$ ), two end resistors are included in the delivery. You place the end resistors in the remaining open data ports. It doesn't matter which ones they are, all data components can be connected in series to each other.

See example connection diagram at the bottom of page 23.

If your component bears a sticker similar to the one shown on the left in the picture, it indicates that it has an integrated end resistor. These devices were manufactured before 2022.

### Relay

The amperage depends on the selected motor power.  
The relay should be mounted with the red wire on the battery side. See connection diagram for more information

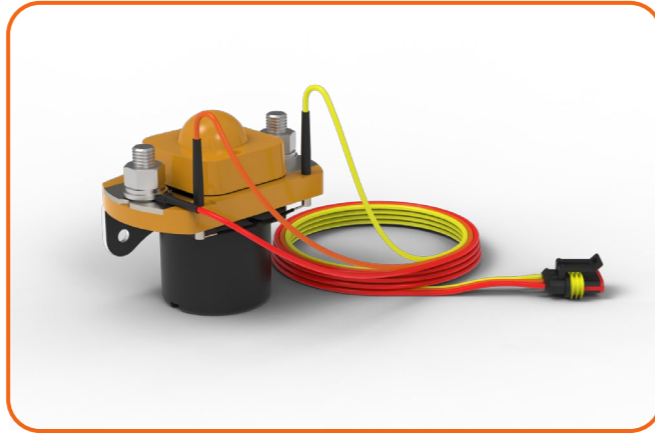

### IMPORTANT!

Not included in the standard scope of delivery are vibration dampers, fuse with fuse holder for the battery cables, main switch, and battery pack with charger. From 2022, WaterWorld supplies its own lithium batteries. Contact WaterWorld or your supplier and inquire about the possibilities.

# CHAPTER 5 SYSTEM INSTALLATION



- Connection diagram
- Placement of the inboard motor
- Batteries
- Battery charger
- Recommended cable thicknesses
- Main power switch
- Main fuse
- The relay
- The throttle
- The display
- The ignition switch
- Connecting the throttle, display, and ignition switch
- Setting up the display
- Testing and commissioning

## Wiring diagram

Connection diagram inboard until 2022

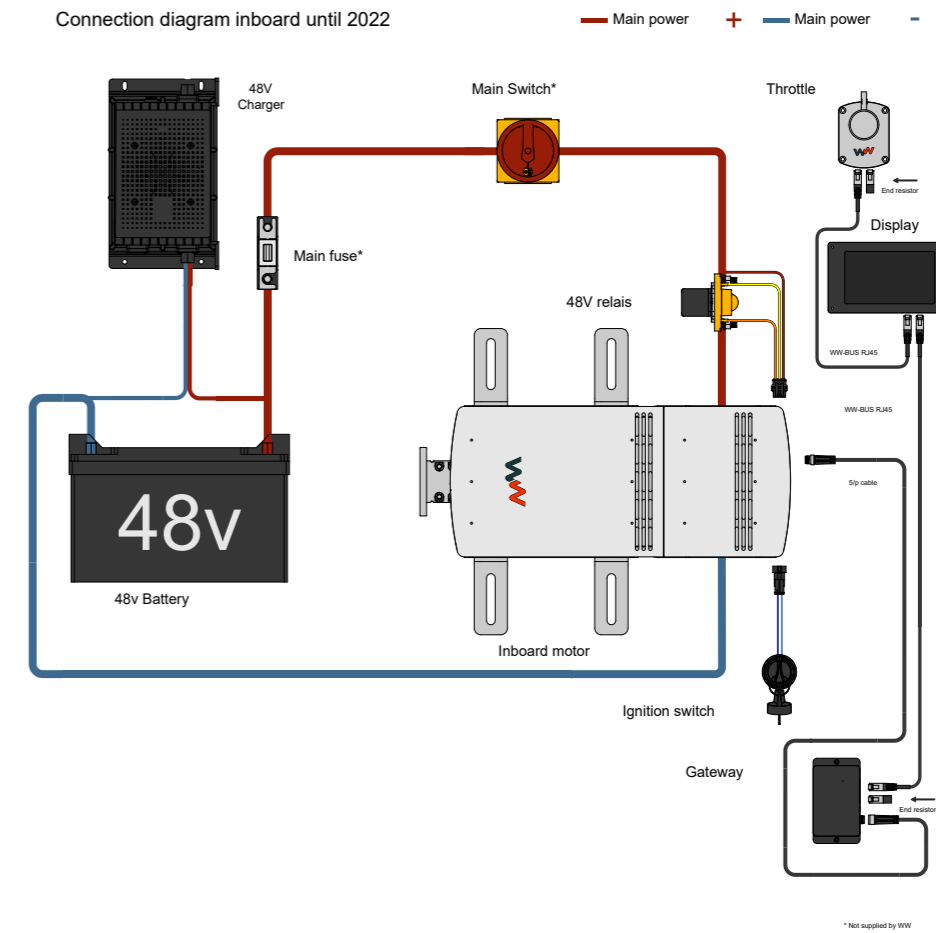

Connection diagram inboard from 2022

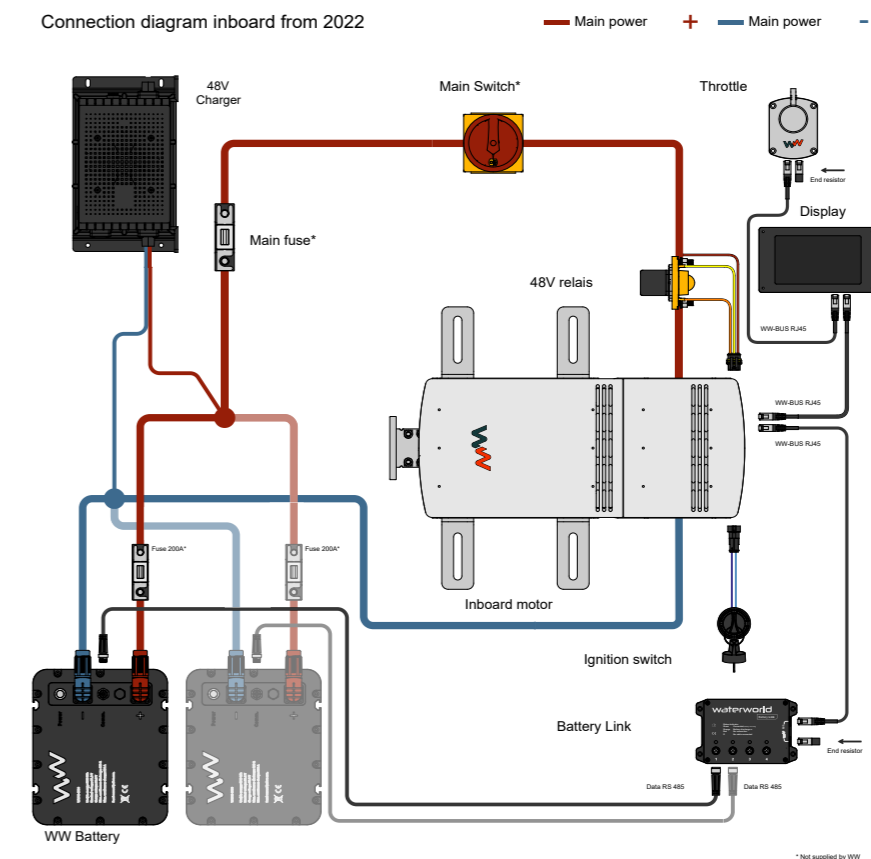

For the latest version of the wiring diagram, please consult our website:  
[www.waterworldelectronics.com/downloads](http://www.waterworldelectronics.com/downloads)

## Placement of the inboard motor

The inboard motor is best installed using the following step-by-step plan:

- Ensure that you stand stably when attaching your propulsion.
- Mount the motor only on land. Mounting the motor in the water may result in material damage.
- Do not lift the WaterWorld system alone, and use a suitable lifting device.
- Connect the throttle and batteries only after mounting the propulsion system on the boat.
- Drilling holes in the hull of the boat can potentially weaken the hull structure. This should be compensated for by adding extra crossbeams, frames, or other reinforcements.
- Depending on the hull structure, a sufficiently large backing plate may be needed between the hull and the locking nuts inside the boat. Ensure that the boat's hull is stable enough to withstand the drive unit and the resulting propulsive forces.

Applying antifouling to the motor is not allowed.  
Remove the motor covers from the motor and carefully place them in a safe location.

The WaterWorld propulsion system is best installed using the following step-by-step plan:

1. Mount the motor on a foundation and vibration dampers that are suitable for absorbing and transferring the thrust of the system to the boat.
2. Preferably, use a flexible coupling between the motor flange and the propeller shaft. This prevents vibrations in the boat and compensates for imperfections caused by the quality of the propeller shaft system or the alignment.

**WARNING! If you choose to mount the motor without vibration dampers, it is crucial that the motor is very well aligned with the shaft, even if you use a flexible coupling. Additionally, this may lead to extra noise, especially in aluminum boats.**

**CAUTION! Due to the weight, it is best to hoist the WW 7.5 or WW 10.0 into the boat. For this purpose, you can rotate the included lifting eye, as shown in the image, also located at the top of the motor where threaded holes are provided. You can use a hoist to lift and lower the motor using this eye.**



**WARNING! Do not lift the WaterWorld system alone, and use a suitable lifting device.**

3. The side supports on the motor are supplied with the supports pointing downward. In most cases, these should be reversed, and the motor will hang in the supports as shown in these two examples:



4. Preferably use a flexible coupling between the motor flange and the propeller shaft. This prevents vibrations in the boat and compensates for imperfections caused by the quality of the propeller shaft system or the alignment.

**WARNING! If the propeller shaft is directly mounted on the motor with a rigid connection, the motor must be very well aligned to prevent damage to the electronics and connectors. Never hit the propeller shaft with a hammer, as this can damage the bearings in your motor! Use a puller for removing the propeller.**

**WARNING! For a WW 7.5, WW 10.0, or WW 20.0 motor in a heavy boat or for professional use with many sailing hours, it is recommended to use an external thrust bearing. This ensures that the rubber motor mounts and the thrust bearing in the motor are not excessively loaded over time. If you have any doubts, please contact your supplier.**

The motor controller of WaterWorld comes with a red and black battery cable already attached to the motor controller side. The red cable on the positive side is connected to the relay.

We recommend and use the following cable thicknesses:

- 4.0i : 35mm<sup>2</sup> cable
- 10.0i : 70mm<sup>2</sup> cable
- 20.0i : 90-120mm<sup>2</sup> cable

You can find more information about cable thickness on page 27 of this manual.

If you are going to use cable lengths longer than 5 meters, we recommend using thicker wiring. The motor and controller are cooled by fans: two or four units at the back of the controller, depending on the motor power (visible at the front of the system), and one on the motor. Ensure that there is free airflow to dissipate heat. The air is drawn in at the front of the motor housing or compartment and expelled at the rear. If necessary, ventilation grilles should be mounted at the top on the side to allow for the intake of fresh air and the exhaust of warm air.

**WARNING! WaterWorld assumes no responsibility for performance loss, damage, or other issues due to inadequate system ventilation.**

In the standard configuration, the motor and controller are mounted in a single frame, and these components are already connected to each other from the factory. You don't need to do anything about it. If there isn't enough space for the controller directly behind the motor, or if batteries are placed above the motor, you can mount the controller separately in another location on the boat. To do this, it can be removed from the frame, and the rear part of the frame can also be removed on both sides. The phase cables may be extended by a maximum of 50% from the factory length. Always consult an expert for this.

**WARNING! If you want to mount the controller externally from the motor, this must be done in consultation with WaterWorld by a certified installer!**



WARNING!

## Batteries

**WARNING! Ensure that there is never any voltage on the system during installation and mounting!**

1. The drive operates on 48 volts. Ensure the battery pack used for this application is suitable in quality and capacity. Use traction, semi-traction - deep cycle, or lithium batteries that meet the specifications.

**WARNING! If there is any doubt about the specifications of lithium batteries, it is advisable to consult with WaterWorld. It is possible that the batteries may damage the motor, or vice versa if they are not compatible with each other.**

2. Place the batteries in the boat so that:
  - a. the weight is evenly distributed and the boat sits level on the waterline
  - b. the batteries cannot slide after installation
  - c. the batteries are accessible for cable connection and future servicing
  - d. the batteries do not obstruct daily use of the boat
  - e. wiring to the motor and charger is easily achievable without unnecessary cable length.
3. Check the individual voltage of all batteries and ensure they are within 0.1 volts of each other before connecting the batteries in parallel. If this is not the case, all batteries must first be fully charged individually
4. Connect the batteries together according to the applicable diagram. Below are examples of 4 x 12 Volt batteries in series and 8 x 6 Volt batteries in series.

**WARNING! Also, refer to the manual of the lithium batteries for correct installation.**

Connecting to 12 Volt batteries

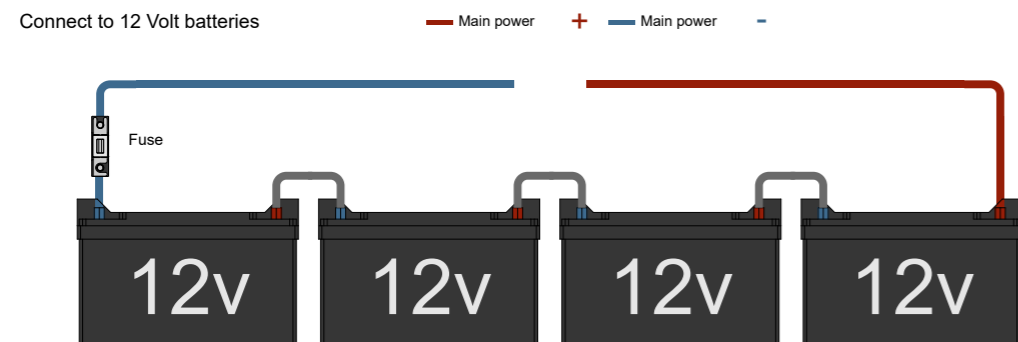

Connecting to 6 Volt batteries

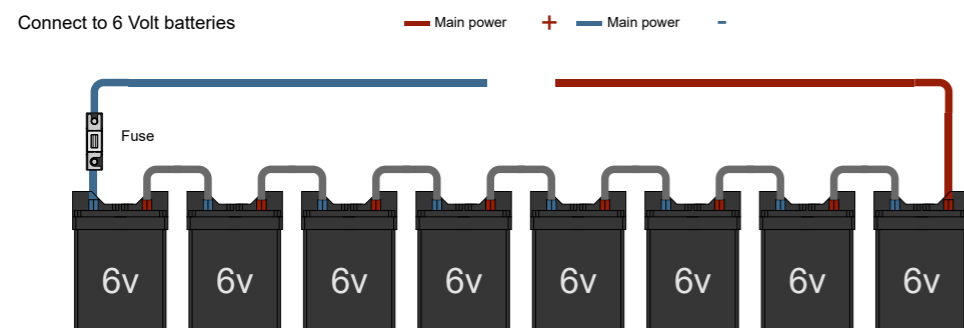

**WARNING! Wait to connect the batteries to the rest of the system until everything is connected and tested for shorts.**

## Battery charger

The battery charger must be chosen according to the battery pack and be suitable in terms of voltage, charging capacity in amperes, battery type, and usage in a boat.



**WARNING! When placing the charger, consider the same factors as with the motor and batteries. Moisture, accessibility, wiring, ventilation, etc.**

**WARNING! If using a WaterWorld battery charger, refer to the charger manual for more information.**

## Recommended cable thicknesses

**Waterworld 4.0i: up to 4.4 kW power consumption, max. 92 Amperes.**  
For a 4.0, a cable thickness of 35 mm<sup>2</sup> is recommended.

**Waterworld 10.0i: up to 11 kW power consumption, max. 230 Amperes.**  
For the 10.0, a cable thickness of 70mm<sup>2</sup> is recommended.

**WaterWorld 20.0i: up to 20 kW power consumption, max 450 Amperes.**  
For the 15.0, a cable thickness of 95-120 mm<sup>2</sup> is recommended.

The above data is based on cable lengths up to 5 meters.  
For further advice on shorter and longer lengths, consult the table below.

Cable Diameter	Cable Section	L(+) + L(-) up to 5 meter	L(+) + L(-) up to 10 meter	L(+) + L(-) up to 15 meter	L(+) + L(-) up to 20 meter
		I max A	I max A	I max A	I max A
0.98	0.75	2.3	1.1	0.8	0.6
1.38	1.5	4.5	2.3	1.5	1.1
1.78	2.5	7.5	3.8	2.5	1.9
2.26	4	12	6	4	3
2.76	6	18	9	6	5
3.57	10	30	15	10	8
4.51	16	48	24	16	12
5.64	25	75	38	25	19
6.68	35	105	53	35	26
7.98	50	150	75	50	38
9.44	70	210	105	70	53
11.00	95	285	143	95	71
12.36	120	360	180	120	90

**WARNING! When determining the appropriate cable thickness, consideration must be given to the voltage drop across the battery cable. This voltage drop must not exceed 0.26 volts, including cable lug shoes. The total length of both positive and negative pole cables must be taken into account.**

## Main power switch

Mount the main power switch in a readily accessible location in the (red) positive cable between the motor controller and the batteries, so that in case of emergency or maintenance, the system can be easily disconnected from the batteries.

**WARNING! The main power switch is not included in the standard delivery scope.**

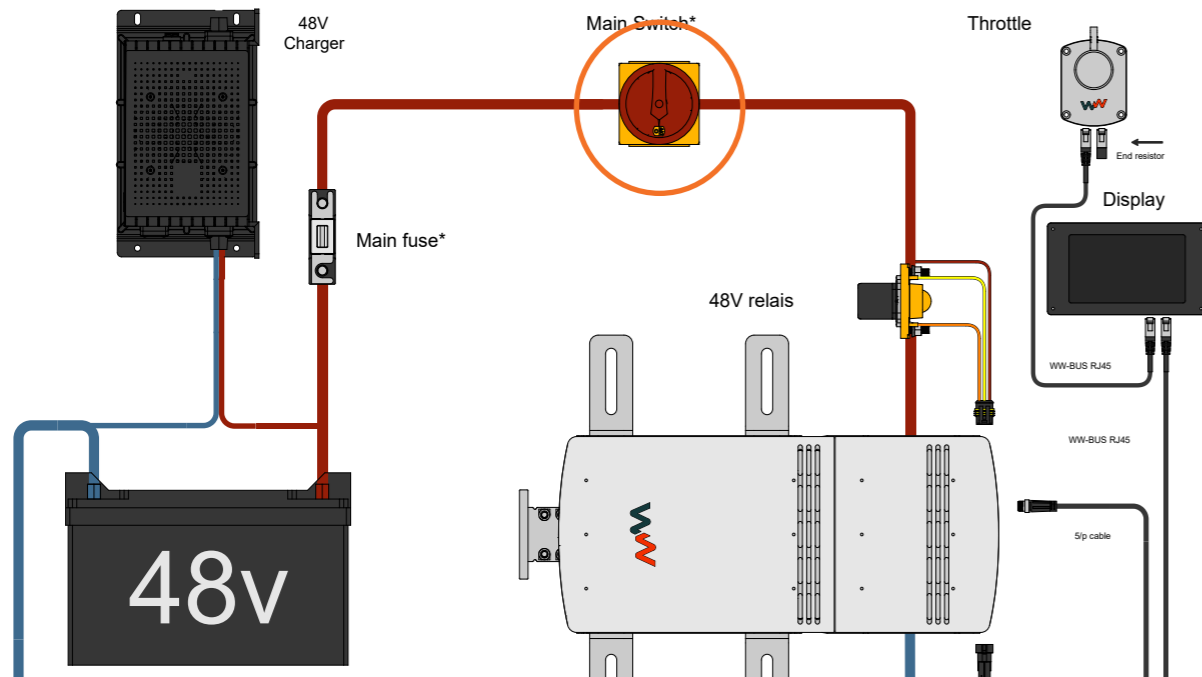

Ensure that the main power switch is always turned OFF ("0" or "off" position) when working on the components and when disconnecting or connecting power cables, once the system is installed.

**WARNING! The main switch should be able to be turned off during battery charging.**

## Main fuse

Install the main fuse between the main power switch and the positive terminal of the batteries, as close as possible to the batteries, preferably in the battery compartment. Ensure that this main fuse is located inside the boat but remains visible by opening a hatch. The capacity of the fuse in amperes should be approximately 1.6 times the maximum amperes of the motor (refer to the specifications).

You can also order an ANL fuse holder and an ANL fuse for the motor right away. We provide the following values:

WaterWorld 4.0i:	160A fuse
WaterWorld 10.0i:	325A fuse
WaterWorld 20.0i:	600A fuse

**WARNING! The main fuse is not included in the standard delivery scope.**

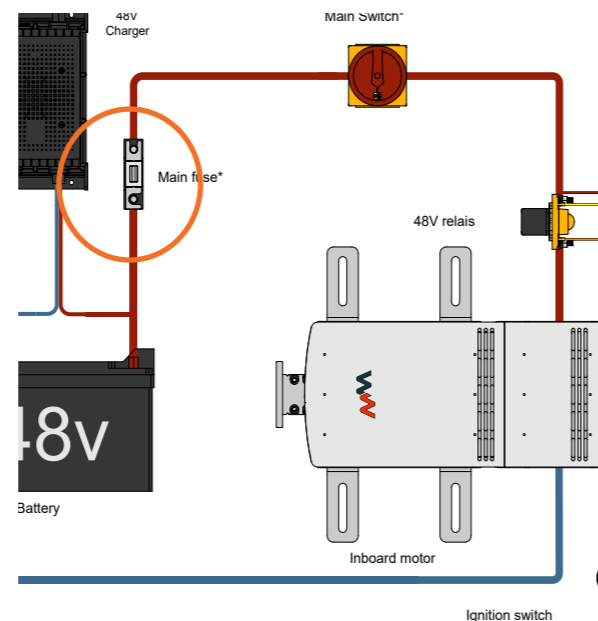

DANGER!

## The relay

Install the supplied relay in the (red) positive cable, between the motor and the main power switch.

The separate red wire with an M8 eyelet should be connected to the relay on the battery side, above the battery cable. Ensure a secure connection for this red wire; a poor connection may result in issues during motor startup.

The relay has a plug with 3 wires, which should be connected to the motor controller using the corresponding connector. The wires have matching colors and fit in only one way.

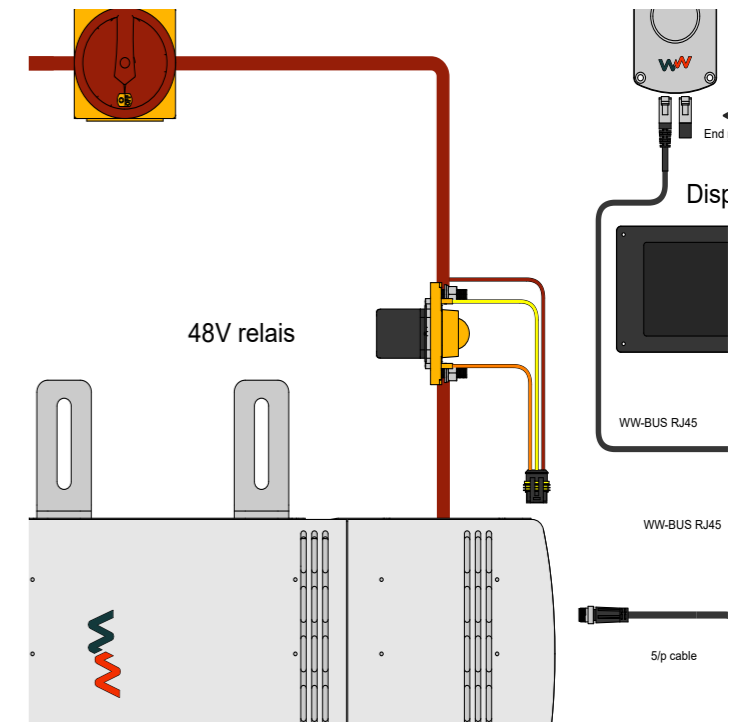

## The throttle

1. Mount the throttle in a suitable location, easily accessible for the driver. Refer to the website for the drawing of the throttle for the correct dimensions.

**Ensure that the throttle is mounted in such a way that crew members of the boat cannot easily bump into it, which could result in sudden acceleration or increased speed!**

2. Mount the throttle in such a way that in the neutral position, the throttle lever is vertical.

**WARNING! The throttle is set as follows by default: moving the lever clockwise moves the boat forward, while moving it counterclockwise moves it backward. This is the correct configuration when the lever is mounted on the starboard side against the steering console.**

When placing the throttle on the port side of the steering console, the operation of the throttle needs to be adjusted in the display menu. If the propeller rotates in the wrong direction, the motor's rotation direction should be adjusted.

**This can be achieved by reversing the phase cables so that the propeller rotates in the opposite direction. Additionally, the position of the throttle in the display can be adjusted. Please refer to the instructions for setting up the display. This adjustment should only be carried out by an authorized dealer or installer. More information can be found on page 31.**

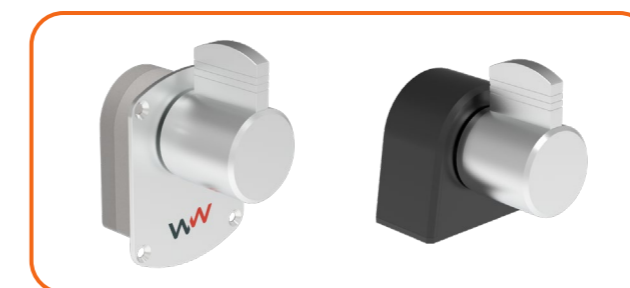

Sidemount (standard)

Topmount



WARNING!



## The display

Mount the display in the appropriate location. It should be clearly visible for the boat's driver. If it is mounted in an open boat, consider that the display can get very hot in direct sunlight. We recommend covering the display adequately and providing ventilation when the vessel is not in use to protect it from weather conditions. When mounting in an aluminum console, ensure the console has (natural) ventilation to prevent moisture from entering through the back of the display.

Make sure you have the correct orientation of the display. Otherwise, it will be upside down.

## The ignition switch

Mount the ignition switch in the appropriate location, easily accessible for the driver, for example, next to the display or below the throttle lever. The cable can be extended if necessary.

## Connecting throttle lever and display (version up to 2022)

The throttle lever, the display, and any other network components, such as a Batterylink, can be connected in various ways. This can be done using the daisy-chain principle. The order in which the components are connected does not matter, as long as a terminating resistor is applied at the last component. The image next to this text shows an example of a connection diagram, with the corresponding step-by-step plan below.

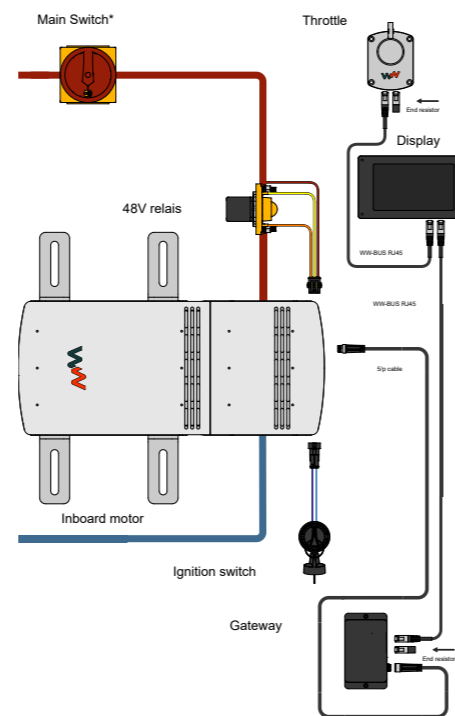

Example connection plan

### Example step-by-step connection plan



1. Connect an RJ45 cable from the throttle lever to the display.
2. Connect an RJ45 cable from the display to the motor controller.
3. Connect the round 5-pin cable from the gateway to the wiring harness on the motor controller.
4. Connect an RJ45 cable from the gateway to the motor controller.
5. Connect the plug from the ignition switch to the connector on the motor controller.

**Starting from 2022 with software version  $\geq$  1.31, only follow steps 1, 2, and 5. Place an end resistor in the remaining contacts.**

### WARNING!

**The terminating resistors are located, in a new delivery, in the RJ45 connectors of the motor controller. Silicone protective covers are placed over the terminating resistors. During the assembly of the boat and the installation of the WaterWorld system, keep these items in place as long as possible. They protect the RJ45 connectors from construction debris.**

## Setting up the WaterWorld display

To start, tap on the settings icon  at the bottom right corner of the screen. The overview screen will appear. Under 'Settings', changes can be made to the settings. After completing each step, press the "save" icon , to save the values! Then, proceed through the different settings:

### Throttle

To the right of "Throttle", you'll see a "1". When two WaterWorld throttle levers are connected, you'll also see a "2" appear. "Mounting side" indicates which side of the steering console the selected throttle lever is mounted on. You can use this to adjust the mounting side to the right, but it doesn't change the rotation direction of the propeller.



### Battery

To the right of "Mode:", you can adjust the setting for the batteries. You can choose from;

- "Off" No battery data is displayed on the screen.
- "CAN" This displays battery information via CAN communication. The measurements from the Batterylink or Smartshunt will be displayed.
- "Standalone" This refers to an unmeasured, set battery capacity. For this, C values must be filled in. Set these C values according to the specifications of the battery. Fill in all values! For lead-acid batteries, if the battery manufacturer only provides a C20 and/or C5 value, then for C10, fill in the average of C5 and C20. For the C1 value, fill in half of the C5 value.



Voorbeeld:

- C20 = 400 Ah
- C10 = 350 Ah (between 20 en C5)
- C5 = 300 Ah
- C1 = 150Ah (50% van C5 value)

### For lithium batteries: all values equal to the C1 value

With each change, the icon  appears in the upper right corner. Click on it when you want to save the changes.

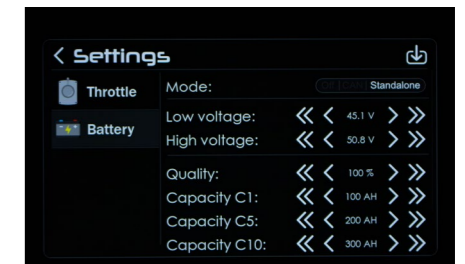

Low Voltage: Set this to the minimum Voltage the batteries can reach. See battery specs for info.  
High Voltage: See Startup ask if full.

"Startup ask if full": Receive a notification at startup asking if the battery is fully charged. This is determined by the "High Voltage" setting.

For WaterWorld batteries, you only need to set "CAN," after which the BatteryLink takes care of all communication. You can then also skip the "High and Low Voltage" settings.

### Screenlock

By tapping on 'Screenlock' in the menu, the main screen is locked. All buttons disappear, and the screen no longer responds to touches. This function is useful when cleaning the display or when it is exposed to moisture. To disable the lock, the padlock icon on the right side of the screen can be slid all the way up.

### Alarm

Under 'Alarm,' all possible warnings and error messages are displayed.

### Info

By clicking on the 'Info' icon, more information about the entire system, the display, the throttle lever, and the battery will appear, including version numbers.

## Setting up the controller for different voltages of lithium batteries

It is possible to use the WaterWorld system with different battery configurations. To do this, a setting on the controller can be modified.

1. If the plug, with green/black cable and indication "44Vdc," is connected to the counter plug on the controller, then the system is suitable for standard voltages. The "cut-off" voltage, the minimum voltage at which the controller stops working, is then 37 Volts. A warning on the display appears from 39 Volts.



2. If the green/black cable is not connected, then the "cut-off" voltage, the minimum voltage at which the controller stops working, is 42 Volts, and the warning on the display appears at 44 Volts.

**WARNING! Many lead-acid batteries go down to a loaded power of 37 Volts.**



### Setting 1

Suitable for: Full-traction batteries, some AGM, and lithium batteries are suitable for this setting. Consult your battery supplier for more information.

### Setting 2

Suitable for: AGM, semi-traction lead-acid batteries, and various lithium batteries.

**WARNING! Improper use of this setting can lead to irreversible damage to the battery pack. WaterWorld is not responsible for damage caused by deep discharge.**

## Step-by-step explanation for testing and commissioning a WaterWorld electric propulsion system

### Step 1: Battery Check

#### Measure battery voltage:

- Check if the batteries are sufficiently charged by measuring the voltage across the terminals of the battery pack using a multimeter. The total voltage should be at least 48 volts, but around 52 volts is expected. For lithium batteries, this can go up to nearly 60 volts.

**WARNING! Ensure that all batteries have the same voltage. The maximum difference allowed is 0.1 volt.**

### Step 2: Preparation

#### - Turn off ignition:

Ensure that the ignition on the dashboard is turned off.

#### - Check throttle lever:

Ensure that the throttle lever is in the neutral position. The display will show a notification if this is not the case.

### Step 3: System Activation

#### - Turn on main switch:

Turn the main switch to "on" or "I".

#### - Activate ignition:

Turn the ignition switch clockwise to turn on the system. You should hear a clear click from the relay.

### Step 4: Engage Forward

#### - Throttle forward:

Gently move the throttle lever one click forward. Check if there is propeller water flow behind the boat.

#### - Check RPM and power:

Check on the display if there is an RPM (revolutions per minute) and power (kW) visible.

#### - Throttle neutral:

Return the throttle lever to the neutral position.

### Step 5: Temperature Check

#### - Check temperatures:

Check the motor and controller temperature on the display. The controller temperature is approximately equal to the temperature of the compartment where the controller is mounted. The temperature of the motor will initially be approximately equal to the outside water temperature.

### Step 6: Shutdown

#### - Turn off ignition

- Turn off main switch:

### Step 7: Connect Shore Power

#### - Connect shore power:

Connect the shore power cable.

#### - Check charger:

Ensure that the charger activates and provides the correct signals according to the charger manual.

#### - Check battery voltage::

CAfter activating the system, check on the display if the battery pack voltage is reaching the prescribed charging voltage. Refer to the battery manual for this information.

### Step 8: First Charging

#### - Charging the battery pack:

Charge the battery pack fully for the first voyage and for setting up the display. See chapter 6 for instructions on using the display.

### Step 9: Conduct Test Run

#### - Perform a test run:

Take a test run and visually inspect everything. Pay close attention to sound and vibrations.

#### - Check RPM and Power:

During the test run, check the number of revolutions (RPM) and kW at full power to determine if you have the correct propeller. The maximum RPM should be between 1400-1500 RPM and the maximum power between 100% and 110% of the nominal specified power.

#### **WARNING!**

- High RPM with low power indicates a propeller that is too small.

- Low RPM with high power indicates a propeller that is too large.

Refer to page 49 for propeller advice.

# CHAPTER 6

## OPERATION OF THE ENGINE



- Turning on and setting off
- Explanation of the display
- Arrival and mooring

### Starting and Departure

1. **WARNING! First, disconnect the shore power connection.**
2. Check if the ignition switch of the system is in the "off" position.
3. Ensure that the throttle lever is in the neutral position.
4. Make sure you have enough free space to set off, or that the boat is securely moored to test the system.
5. Turn the main switch to "on" or "I".
6. Turn the ignition switch clockwise to turn on the system. You may hear a "click" from the activating relay.
7. Check if the display turns on and shows the correct information.
8. Verify if the throttle lever operates correctly in the neutral, forward, and reverse positions.
9. Gently engage the throttle lever forward or backward and apply a little throt.
10. We wish you a safe journey!

## Explanation of the display

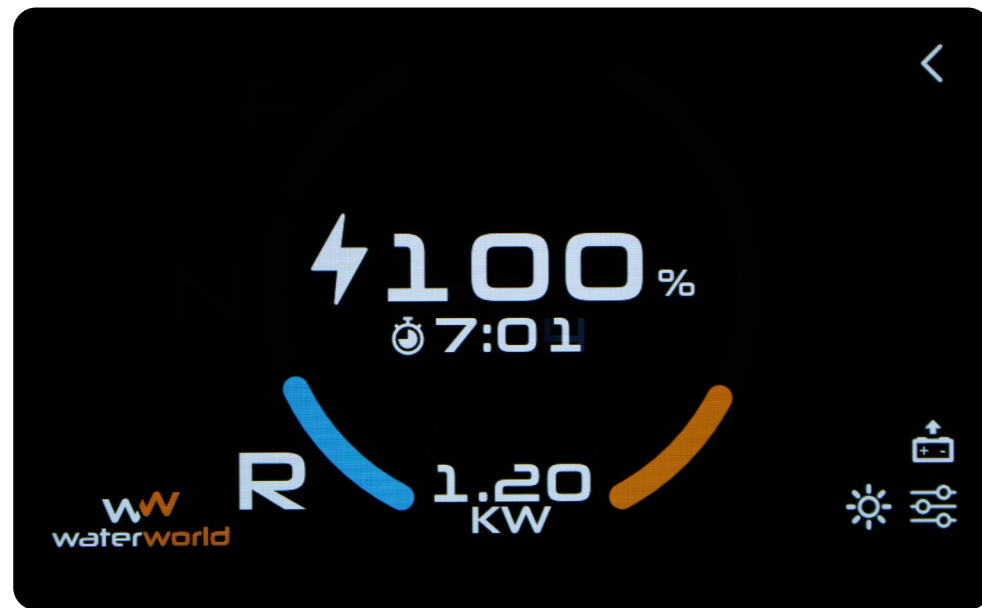

figure 1.0

The display provides a clear overview of the key parameters for operating the electric propulsion. The information on the display in figure 1.0 is as follows:

- Battery level: 100% charged
- Time: 7:01. This is the time that can still be sailed with the current consumption, based on the specified battery capacity. When the battery is being charged, you will not see the time.
- Direction: The propulsion is in reverse, indicated by the "R" on the left side of the display. "N" is neutral and "F" is forward. The blue radius icon indicates that the throttle lever has instructed the controller to rotate in reverse. This is a so-called "feedback" signal.
- Power: The current consumption is 1.18 kW. When the power is less than 1 kW, the display indicates the power in watts. Here, the orange radius icon represents power sent from the throttle lever to the controller. A half circle represents 100% power.

Additionally, there are several icons on the right side of the display:

### Iconen op het Display

- **Icons on the Display:** This icon is used when you have entered a standalone battery. It allows the State of Charge (SoC) percentage to be corrected to 100% after the charger has fully charged the battery. Refer to the charger's user manual for this.
- **Sun icon:** This allows you to adjust the brightness or illumination of the display.
- **Settings icon:** This icon provides access to advanced settings or configurations.
- **Arrow icon:** This allows you to slide in a menu from the right side of the screen that provides information about the engine and, when connected to CAN, the battery(ies)

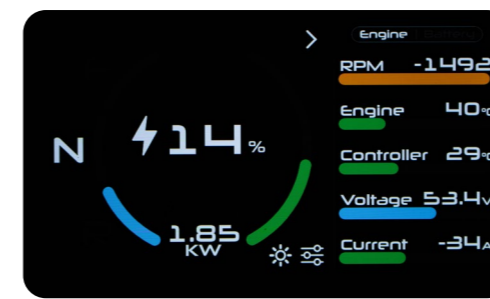



figure 1.1

By tapping on the arrow icon  at the top right of the display, a screen slides in from the right with information about the engine, "Engine", and possibly the battery, "Battery", when communicating via CAN

- "RPM": Engine revolutions per minute
- "Engine": Engine temperature in degrees Celsius
- "Controller": Controller temperature in degrees Celsius
- "Voltage": Bus voltage in Volts
- "Current": Current drawn in Amperes measured by the controller
- "Phase": Phase current measured on the bus in Amperes



figure 1.2

In the bottom right corner of the screen, you can see a little sun (Figure 1.2). By clicking on it, you can adjust the brightness of the screen. Next to the sun, there's the settings icon.

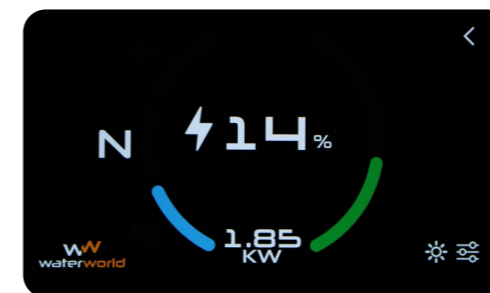



figure 1.3

In contrast to figure 1.0, in figures 1.1 and 1.3, you see a green radius bar on the right side of the screen instead of an orange one. This indicates that, if your system is capable, it is generating power that is being stored in the battery(ies). In this case, 1.85 kW is the generated power. At this moment, you also don't see a time because it is "infinite" as long as you are regenerating.



figure 1.4

When you click on , you will be taken to the screen where you can learn more about;

- "Settings"
- "Screenlock"
- "Alarm"
- "Info"

(Figure 1.4). More about this on page 42.

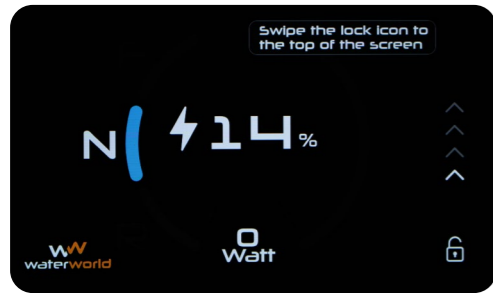

figure 2.0

### “Screenlock” (Figure 2.0)

When you press the “Screenshot” icon, you return to the main screen and most icons disappear. You can read the most important data, but the screen cannot be operated. To exit the “screenlock” function, you need to swipe the arrows from bottom to top on the right side of the screen in one smooth motion

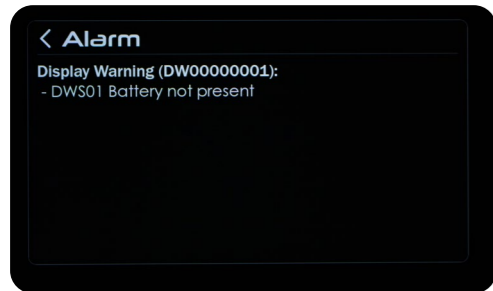

figure 2.1

### “Alarm” (Figure 2.1)

In case of a malfunction, a flashing hazard triangle appears at the bottom of the display, orange or red, depending on whether it is a warning or an error.

To see what the error message means, you can tap on ‘Alarm’ in the menu. Refer to chapter 9 for an overview of all warnings and errors.



figure 2.2

### “Info” (Figure 2.2 & 2.3)

Under “Info”, you can find all information about;

- “Engine”
- “Display”
- “Throttle”
- “Battery”.

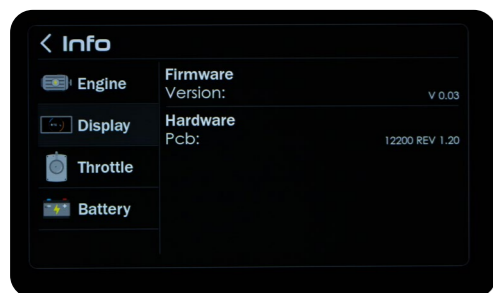

figure 2.3

This information may include;

- Software versions
- Firmware versions
- Hardware versions
- Hardware names

When discussing your system with your supplier, having this screen available is handy.

## Arrival and mooring

1. Ensure that after mooring and securing the boat safely, the throttle is in the neutral position.
2. Turn off the system using the ignition switch.
3. Now, switch off the main power switch.

**WARNING! Also turn off the system using the main power switch when swimming around the boat or when repairs or maintenance are being performed on the boat**

4. Connect shore power and check the proper operation of the battery charger.

# CHAPTER 7

## MAINTENANCE AND SERVICE



- Checks during the sailing season
- Annual inspections by you or your supplier
- Winter storage
- Use the motor in saltwater

### Checks during the sailing season

Regularly pay attention to your WaterWorld propulsion system and its associated energy system, even during the boating season. We recommend focusing on the following points:

#### - Moisture and Condensation:

Ensure that the area where the motor controller is installed remains free from moisture and condensation. If there is water in the boat and the electronics have gotten wet, dry them off and contact your installer. Do not turn on the system in this situation! Excessive condensation in the areas where WaterWorld components are installed indicates insufficient ventilation; in that case, provide additional ventilation.

#### - Motor Cables:

Regularly check the motor cables for wear.

#### - Lead-Acid Batteries:

When not sailing, keep your system connected to shore power as much as possible to prevent the batteries from draining. The battery charger will automatically stop when the batteries are full. When turning the system on, check that the battery charger activates. We recommend disconnecting shore power during thunderstorms.

#### - WaterWorld Batteries or Other Lithium Batteries:

Carefully consult the manual for these batteries for specific instructions and recommendations.

**WARNING! Always turn off the main power switch before cleaning or inspecting the system.**

## Annual inspections by you or your supplier

Preferably, have your system inspected annually by your supplier or installer. They will check the system for the following points:

### - Proper Functioning of All Components:

Ensure that all parts are functioning correctly.

### - Moisture Problems and Corrosion:

Check for any moisture issues and corrosion on contacts, battery terminals, and/or connectors. Apply contact spray preventively and grease battery terminals if necessary.

### - Tightening of Terminal Clamps and Connectors:

Ensure all terminal clamps and connectors are securely fastened.

### - Tightened Mounting Bolts and Nuts:

Make sure all mounting bolts and nuts are firmly tightened.

### - Damage to Cables and Components:

Inspect for any damage to cables and components.

### - Condition and Voltage of All Batteries:

Check the condition and correct voltage of all batteries\*.

#### Under Load:

- If you have a multimeter, check the voltage of each battery by setting the meter to the voltage setting and placing it on the positive and negative terminals of one battery while the motor is running. The difference between the batteries should not exceed 0.1 volts. If it does, contact your supplier or installer.

#### Without Load:

- After charging, measure the batteries individually again and check that there is no significant difference between them. Refer to your battery specifications or consult your supplier to ensure the voltage is sufficient.

### - Imbalance in the Motor/Propeller Shaft System:

Check for any imbalance in the motor or propeller shaft system.

### - Correct Settings of the Display:

Ensure the display is correctly set.

**\* Note: These checks apply to lead-acid batteries connected in series.**

## Winter storage

During and after winter storage, the same recommended checks as in the previous inspections apply.

For lead-acid batteries, it is especially important to ensure that the batteries are charged and remain charged.

### - If a power source is available:

If there is a power source available for your boat during winter storage, keep the shore power connected. The charger will automatically turn on and off as needed. However, it is advisable to check the boat and batteries at least twice during the winter to ensure that the charger is connected and that there is still sufficient voltage in the batteries.

### - If no power source is available:

If there is no power source available for your boat, make sure the boat is stored with fully charged lead-acid batteries. Then disconnect the main positive and negative terminals of the battery pack to ensure that no device is connected to the battery packs.

Refer to the battery manual for more information about winter storage.

## Use of the inboard motor in salt water

When using in saltwater, it's important to pay extra attention to the following points:

### - Sealing of Enclosures:

Ensure that the enclosure(s) are properly sealed against saltwater.

### - Ventilation:

Ensure that these areas are well ventilated.

### - Corrosion Inspection:

Regularly inspect all components, especially the contacts, for corrosion.

### - Cleaning:

Thoroughly clean the components twice a year.



# CHAPTER 8

## TECHNICAL SPECIFICATIONS



- **Motor Specifications**
- **Electric Motor**
- **Motor Controller**
- **Control Lever**
- **Relay**
- **Display**
- **Propeller Selection Guidelines**

### Motor Specifications

Model	WW 4.0i	WW 10.0i	WW 20.0i
Max. Power Consumption (S1)	4,4 kW	11 kW	20 kW
Max. Rotational Speed (rpm)	1450	1450	1450
Voltage	48 Volt		
Maximum Current (Ampères))	92	230	450
Type	Asynchronous		
Sensor	Sensorless		
Weight (kg)	39	76	100
IIP rating motor	IP 65		
IP rating controller	IP 65		

**WARNING! Current may temporarily increase during acceleration.**

### Electric motor

Voltage: 3 X 34 Vac @ 50 Hz  
 Rotational speed: 1350 / 1450 RPM (dependent on the motor type)  
 Max rotational speed: 1500 RPM  
 Insulation Class: H (185 °C)  
 Thermal Protection: PT 84-130 °C  
 Maximum temperature: 135 °C  
 Output shaft: 28MM / 38MM (dependent on the motor type)  
 Cooling: Air-cooled, fan on shaft

### Motor Controller

Voltage: 48 Volt  
 Maximum temperature: 80 °C  
 Cooling: Air, 2 / 4 times fan (depending on the motor type)  
 Control of the electric motor: Sensorless

### Control lever

Type: WaterWorld CANopen control.  
 Controller: Based on rotation and hall sensors.  
 Potentiometer + hall sensor for additional control and safe operation.  
 Communication: CANopen

### Relay (only for 10.0i and 20.0i)

Voltage: 48V DC  
 Maximum Continuous Current: >400A

## Display

Power supply via motor controller.

In the attachments of this manual, you will find the dimensional drawings of the various models of WaterWorld motors. You can find the drawings and also 3D files on [ww-el.com](http://ww-el.com).

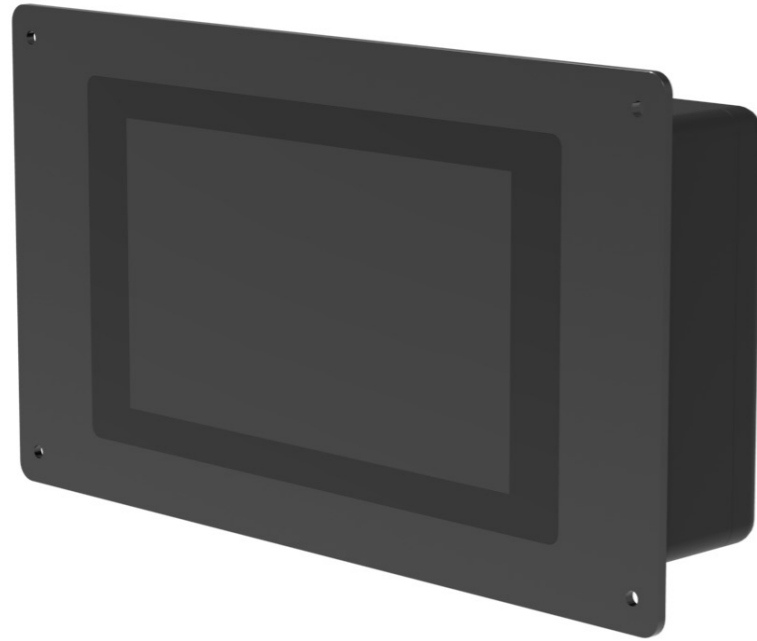

## Propeller Selection Guidelines

Below are guidelines for choosing a propeller size. The type and brand of the propeller can influence the sound it produces when rotating. For the correct choice, contact an expert in this field.

Note: The optimal propeller for an individual boat may vary from this, as each boat is different.

For a 4.0i system and a boat that travels at speeds slower than 11 km/h.

- 12 x 7 3-blade propeller
- 12 x 8 3-blade propeller

For a 4.0i system and a boat that travels faster than 11 km/h.

- 12 x 8 4-blade propeller

For a 10.0i motor and a boat that travels at speeds slower than 10 km/h.

- 14 x 9 3-blade propeller

For a 10.0i system and a boat that travels faster than 10 km/h.

- 14 x 10 3-blade propeller
- 15 x 9 3-blade propeller
- 14 x 10 4-blade propeller (only for lighter boats)
- 15 x 9 4-blade propeller (only for lighter boats)
- 16 x 8 3-blade propeller (only for lighter boats)

20.0i system for lower speeds (approximately 11 km/h).

- 14 x 11 3-blade propeller
- 16 x 9 3-blade propeller
- 16 x 9 4-blade propeller
- 15 X 10 4-blade propeller

20.0i system for higher speeds (approximately 15 km/h).

- 15X 11 3-blade propeller
- 16X 10 4-blade propeller

# CHAPTER 9 FAULTS AND ISSUES



- **Error codes for malfunctions**
- **Warnings**
- **Errors**
- **Issues**

## Error codes for malfunctions

In case of malfunctions, a flashing hazard triangle with an exclamation mark appears at the bottom of the display:

### - Orange exclamation mark:

This indicates a warning. The system is not functioning properly, but can still be used. Depending on the warning, power may be reduced.

### - Flashing red hazard triangle:

This indicates a critical error. The system is currently not functioning correctly.

### Viewing Error Messages

- Open the menu and select 'Alarm' to see what the error message means.

### Inspection for Error Messages

- Check the data on the display, including temperature, voltage, smooth operation of the propeller shaft, installation, and connections of all wiring.

- If the problem cannot be resolved, contact your supplier.

### Possible Warnings and Errors

Below are the possible warnings and errors:

## Warnings

### Engine warning (EW)

	Indication	Meaning	Solution
EWS01	No fan feedback	No feedback from fans.	Check the fans and their connections.
EWS02	Controller temperature to high	The controller temperature is too high.	Check the fans or reduce the power.
EWS03	Controller temperature to high (Limited power)	The controller temperature is too high. (Limited power)	Check the fans or reduce the power.
EWS04	Motor temperature to high	The motor temperature is too high.	Check the fans or reduce the power.
EWS05	Motor temperature to high (Limited power)	Motor temperature is too high. (Limited power)	Check the fans or reduce the power.
EWS06	Phase current to high	Phase current is too high.	Reduce the power.
EWS07	Throttle not present or neutral	Throttle absent or neutral.	Connect a throttle to the controller and set the throttle to neutral.
EWS08	No valid system parameters loaded	No valid system parameters loaded	Please contact the supplier.
EWS09	Position sensor fault (Sensorless drive active)	Position sensor error. Sensorless operation is possible.	Connect the position sensor or replace it. Turn off the controller and then back on again.
EWS10	Charging disabled (Position sensor fault)	Battery charging disabled due to position sensor error.	Remedy the position sensor error.
EWS11	Controller temperature sensor read fault	The temperature of the controller cannot be read.	Please contact the supplier.
EWS12	Motor temperature sensor not present	The motor temperature sensor is not connected.	Connect the motor temperature sensors to the controller.
EWSnn	Please contact supplier	There is a warning, but the screen has outdated firmware. EWSnn contains the warning number.	Check the warning number with the supplier.

## Battery Warning (BW)

Code	Indication	Meaning	Solution
BWS01	Temperature to low	Temperature is too low	Use the battery in a warmer environment.
BWS02	Temperature to high	Temperature is too high.	Let the batterij cool down.
BWS03	Bus voltage to low	Bus voltage is too low.	Charge the battery.
BWS04	Bus voltage to high	Bus voltage is too high.	Stop regeneration (from the motor).
BWS05	Bus current to high	Bus current is too high.	Reduce power / Reduce number of devices.
BWS16	Vendor specific: 0x<value>	Supplier specific: 0x<value>	Please contact the supplier.

## Display warning (DW)

Code	Indication	Meaning	Solution
DWS01	DWS01 Battery not present	There is no battery present.	Check the communication cable connection with the battery coupling.
DWS02	DWS02 No valid system parameters loaded	No valid parameters loaded.	Please contact the supplier.
DWS03	DWS03 Battery voltage to low, drive slowly	The battery voltage is too low, drive (sail) slowly.	Sail slowly.
DWS04	DWS04 Standalone battery monitor not initialized	Independent battery monitor not installed.	Reset the battery capacity to 100% (button in main menu).

## Errors

### Engine faults (EF)

Code	Indication	Meaning	Solution
EFS01	EFS01 Configured motor type not supported	Configured motor type is not supported.	Please contact the supplier.
EFS02	EFS02 Configured motor current is too high	Configured motor current is too high.	Please contact the supplier.
EFS03	EFS03 Hardware is not supported	Hardware is not supported.	Please contact the supplier.
EFS04	EFS04 No valid parameters loaded	No valid parameters loaded.	Please contact the supplier.
EFS05	EFS05 No valid motor parameters loaded	No valid motor parameters loaded.	Please contact the supplier.
EFS06	EFS06 Serial not present	Serial is not present.	Please contact the supplier.
EFS07	EFS07 Controller temperature sensor not present	Controller temperature sensor is not present.	Please contact the supplier.
EFS08	EFS08 Controller temperature sensor not configured	Controller temperature sensor is not configured.	Please contact the supplier.
EFS09	EFS09 Controller temperature to high (Shutdown)	Controller temperature is too high. (Shutdown)	Let the controller cool down and then try again.
EFS10	EFS10 Motor temperature sensor not present	Motor temperature sensor is not present.	Connect the motor temperature sensor to the controller.
EFS11	EFS11 Bus current to high (Shutdown)	Bus current is too high. (Shutdown)	Turn off the controller and then back on again.
EFS12	EFS12 Bus voltage to low (Shutdown)	Bus voltage is too low. (Shutdown)	Check the battery voltage and then turn off and on the controller.
EFS13	EFS13 Bus voltage to high (Shutdown)	Bus voltage is too high. (Shutdown)	Check the battery voltage and then turn off and on the controller.
EFS14	EFS14 Position sensor fault	Position sensor error.	Connect the encoder/hall sensor of the motor to the controller.
EFS15	EFS15 Parameters config not supported	Parameter configuration is not supported.	Please contact the supplier.

## Throttle fault (TF)

Code	Indication	Meaning	Solution
TFS01	No valid parameters loaded	No valid parameters loaded.	Please contact the supplier.
TFS02	Serial not present	Serial is not present.	Please contact the supplier.
TFS03	Parameters config not supported	Parameter configuration is not supported.	Please contact the supplier.

## Display fault (DF)

Code	Indication	Meaning	Solution
DFS01	DFS01 No valid parameters loaded	No valid parameters loaded.	Please contact the supplier.
DFS02	DFS02 Serial not present	Serial is not present.	Please contact the supplier.
DFS03	DFS03 Engine not present	The engine is not present.	Check if the motor controller is turned on. Verify the communication cable to the motor controller.

## Issues

Below are discussed some possible issues and their solutions.

### My engine is losing power rapidly:

#### 1. Battery pack nearly empty:

- Check the remaining percentage on the display along with the voltage while the motor is running.
- If the voltage drops below 46 volts, the motor will reduce power.
- Once the voltage drops below 42 volts, depending on the settings, the motor may stop completely.

#### 2. Insufficient cooling:

- If the motor overheats, it will reduce power and eventually stop.
- Common causes include a heavy running propeller shaft or an oversized propeller.
- Also, check if there is any line or rope caught in the propeller.

### **WARNING! Turn off the system before approaching the propeller shaft!**

#### My motor vibrates and/or makes excessive noise

##### 1. Propeller damage:

- Check for damage to the propeller beneath the boat.

##### 2. Insufficient water flow to the propeller:

- Check for any obstruction in front of the motor that hinders water flow.

#### My motor has reduced power

##### 1. Propeller issues:

- Check if there is anything stuck in the propeller or if it is unbalanced
- The propeller may be too large.

### **WARNING! Turn off the system before putting your hands near the propeller shaft!**

#### I have lost my key

- Always have a spare key. Get one made if you have lost one.
- If you need a new key, contact your supplier.

# CHAPTER 10 WARRENTY



- **Warranty periods**
- **Warranty terms**
- **Warranty procedure**
- **Disposal of the product / recycling**

## Warranty periods

The warranty period is 24 months and covers all components of the WaterWorld system. When you have combined a WaterWorld system with WaterWorld lithium battery(ies), the warranty period is 36 months. The warranty period begins from the day of delivery of the WaterWorld system to the end customer.

For WaterWorld systems used commercially, even temporarily, there is a modified warranty period of one year from the delivery of the product to the customer.

In all cases, the right to warranty expires six months after discovery of any defect.

## Warranty terms

Water World Electronics BV guarantees the end user of a WaterWorld system that it is free from material and manufacturing defects during the warranty period. WaterWorld will cover the costs to remedy any material or processing defect for the end customer.

This cost coverage does not apply to any incidental expenses arising from a warranty case, nor to any other financial losses (e.g., towing costs, cranes, telecommunications, meals, lodging, loss of use, time loss, etc.).

Travel and/or transportation costs are not reimbursed by WaterWorld Electronics BV.

WaterWorld Electronics BV decides whether defective parts will be repaired or replaced. Distributors and dealers performing repair work on WaterWorld motors do not have the authority to issue legally binding statements on behalf of WaterWorld Electronics.

Wear parts and routine maintenance are excluded from the warranty. Cables and fastening materials are also excluded from the warranty.

### Your supplier or WaterWorld has the right to refuse warranty when:

- The warranty claim was not submitted according to the instructions (see warranty procedure).
- The product was not handled according to the instructions.
- The safety, usage, and maintenance instructions from the manual were not followed.
- Prescribed maintenance was not performed or documented..
- The product is damaged due to external influences, an accident, or where the defect is not attributable to WaterWorld in any way.
- The WaterWorld system has been modified, altered, or equipped with parts or accessories that are not explicitly permitted or recommended by WaterWorld.
- Prior servicing or repair work was not carried out by WaterWorld authorized companies or original spare parts were not used, unless the customer can demonstrate that the circumstances leading to the warranty refusal did not affect the occurrence of the defect.

## Warranty procedure

Adherence to the warranty procedure described below is a condition for making a warranty claim.

- Contact your WaterWorld supplier in case of a complaint.
- Keep your purchase invoice handy, as the supplier will need it to verify where and when your WaterWorld system was purchased.
- **NOTE! Your purchase receipt or invoice is your proof of warranty. Therefore, keep it safe after purchase!**
- Also, have the serial number of the motor available, if it is not already listed on the purchase invoice.
- Provide a clear description of the complaint, the circumstances under which it occurs, and any other relevant information that can help your supplier assess the nature and severity of the issue. If possible, take photos of the system and the overall situation that may assist.
- Your supplier may ask you to perform additional checks on the system before assessing the complaint thoroughly.
- When transporting products to the WaterWorld supplier, ensure correct handling as incorrect transport is not covered by warranty.

## Disposal of the product / recycling

The WaterWorld motors are designed in accordance with EU Directive 2012/19/EU. This directive governs the recycling of electrical and electronic equipment to protect the environment. Disposed electrical and electronic equipment should not be thrown away with normal household waste, as it can release harmful substances into the environment, which can affect the health of humans, animals, and plants. These substances accumulate in the food chain and the environment, leading to the loss of valuable resources. In accordance with regional regulations, you can deposit the motor at a collection point where it will be recycled in an environmentally responsible manner



# CHAPTER 11 APPENDICES



- Ray-link
- Connection diagram Ray-link
- VE-link
- Connection diagram VE-link

## Ray-link Integration with Raymarine Axiom+ Multifunction Display

It is possible to connect the WaterWorld system to a Raymarine Axiom+ multifunction display using a WaterWorld Ray-link. Follow the steps below to make the WaterWorld page visible on the screen of the Raymarine Axiom+.

### 1. Placement of the Ray-link:

Ensure that the Ray-link is installed correctly to make the WaterWorld page available on the Raymarine Axiom+ display.

### 2. Accessing the WaterWorld page:

- From the main page, select the dashboard.
- In the top right corner of the dashboard, you will find a button with three horizontal lines stacked vertically.
- Click on this button to open the option to select the WaterWorld page.
- Choose the WaterWorld page to set it as the main dashboard.
- Note: The WaterWorld page must be installed beforehand. Please inquire with your supplier..

### 3. Required parts for installation:

- Raymarine SeaTalkng Starter Kit
- A06045-cable
- RJ45-cables
- The Raymarine Axiom+ multifunction display comes with a shorter version of the A06045 cable.

### 4. Connecting the cables:

- Ensure all cables are connected correctly according to the illustration below.
- Place end resistors in any remaining RJ45 openings.

These steps enable you to integrate and display the WaterWorld page on your Raymarine Axiom+ multifunction display, providing easy access to all relevant information from the WaterWorld system.

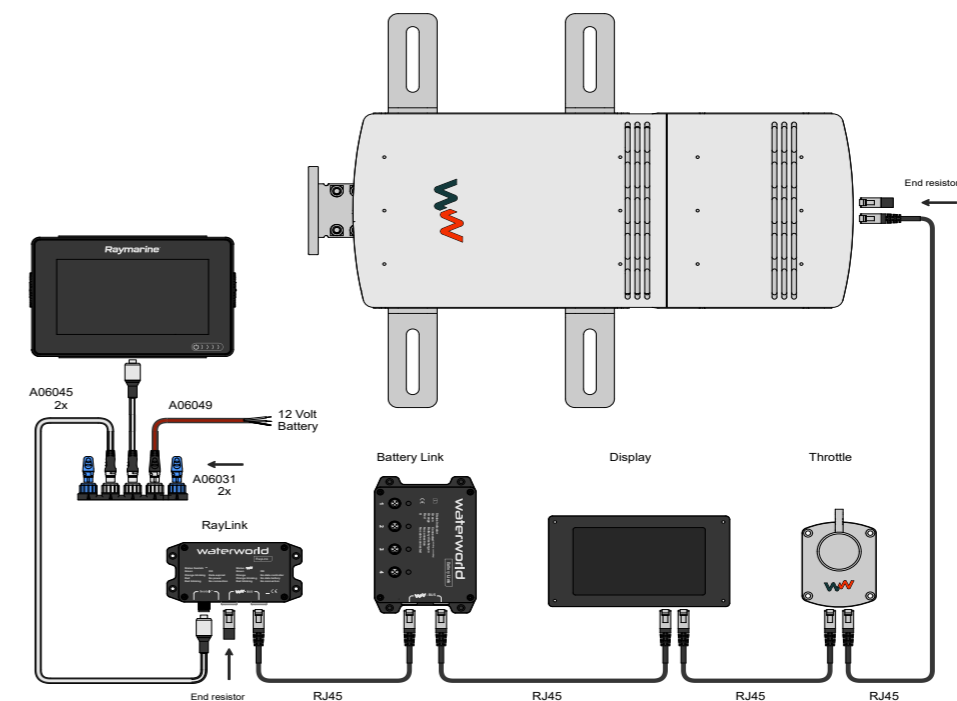

**WARNING!** Refer to the manual of the Raymarine Axiom+ multifunction display at [www.raymarine.com](http://www.raymarine.com) for correct screen installation.

## VE-link

### Integration with Victron SmartShunt

When a WaterWorld system is installed and a Victron SmartShunt is used, these systems can be connected via a VE-link. The SmartShunt acts as a battery monitor, measuring battery voltage and current. Based on these measurements, it calculates the battery's state of charge and remaining time. Additionally, it records historical data such as deepest discharge and average discharge. By installing a VE-link, all this data can be displayed on the WaterWorld display.

### Installation of the VE-link

#### 1. Connecting the VE-link:

- The VE-link has an opening for the VE-direct cable. Connect this cable to the SmartShunt.
- Use RJ45 cables in the remaining openings of the VE-link to establish connections with the controller and the display. Refer to the connection diagram below for correct connections.

#### 2. Display configuration:

- After all cables are connected according to the diagram, a setting on the display needs to be changed to view the retrieved data..
- Go to settings by clicking on the gear icon at the bottom right corner of the screen.
- Click on 'Battery'.
- Under 'Mode', select the 'CAN' option.
- An icon will now appear at the top right of the menu. Click on it to save the adjustment.

After completing these steps, the information from the SmartShunt will be displayed on the WaterWorld display, providing easy access to all relevant battery data..

### Connection diagram

Ensure you follow the correct connections as per the provided connection diagram to ensure proper linkage between the VE-link, the SmartShunt, the controller, and the display.

**\* Note: At the time of writing, the VE-link only works with the first generation of Victron SmartShunt.**

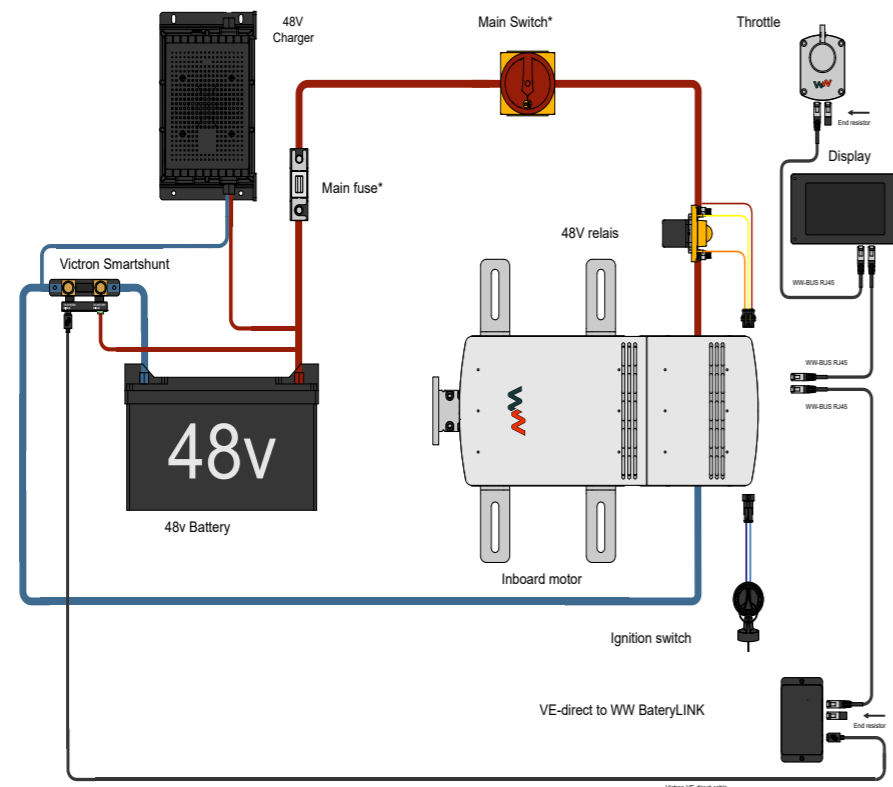

**WARNING! Refer to the manual of the Victron SmartShunt at [www.victronenergy.com](http://www.victronenergy.com) for mounting and setting up the SmartShunt, and using the VictronConnect app.**





**Questions? Feel free to contact us.**

**Contactinformation**

Water World Electronics  
Weerdijk 14 – 8375 AX Oldemarkt

[info@waterworldelectronics.com](mailto:info@waterworldelectronics.com)

Telefoon: +31(0)561 451 636